

Wireless High Bay Sensor (WHS100)

Installation Instructions

The Daintree Networks® WHS100 Wireless High Bay Sensor is a line powered control component within the ControlScope® wireless building controls platform. It enables wireless control of individual luminaires and has an integrated motion sensor. It comes with interchangeable sensor lenses to provide occupancy based control for high, medium, and low mount lighting applications.



The WHS100 provides ON/OFF and 0-10V dimming control of ballasts and LED drivers. Its wet location rating and mounting through a standard ½" knockout, allows installation on a variety of indoor and outdoor fixture types.* Model WHS100 mounts to the side of a fixture; WHS100-BM (Base Mount) mounts to the bottom of a fixture.

The WHS100 contains a standard ZigBee radio that operates seamlessly with other standard ZigBee wireless products in the ControlScope system. The WHS100 serves as a ZigBee mesh network router, includes the capability to monitor and measure the energy consumption of the lighting load being controlled, and enables automatic fault detection.



WARNING: Risk of electrical shock



Before starting the installation, be sure that all power to the fixture is turned OFF.

- Keep the sensor lens clean.
- Avoid touching the PIR sensor element.
- After powering the sensor, allow up to three minutes for initialization.

Installation Process

1. Determine the mounting location. See [Mounting](#).
2. Record the sensor's IEEE address and location on the facility floor plan. Make sure the IEEE number will be visible after the sensor is mounted. See [IEEE Address Labels](#).
3. Remove the tightening ring from the threaded nipple.
4. Insert the sensor wires and threaded nipple through the knockout on the fixture.
5. Thread the sensor wires through the tightening ring and screw the ring onto the nipple on the inside of the fixture to secure the sensor to the fixture wall.
6. Wire the sensor to the line voltage supply and 0-10V dimming input to the driver or ballast. See [Wiring](#).

* In wet locations, the fixture or enclosure must be watertight.

7. Apply power to the fixture. After initialization, the Green LED flashes each time occupancy is detected.

8. Reset the WHS100: press and hold the Utility button for 5 seconds. Release the button when both the red LED and the green LED begin to flash rapidly.

The red Network LED flickers while the WHS100 attempts to join a ZigBee network. If it is unable to join, it automatically retries every 20 seconds until it succeeds. When successful, the red LED either flashes slowly, or if the WHS100 is already assigned to a zone, the red LED is off. See [LED Operation](#).

Note, the sensor will not be able to join a network until a Wireless Area Controller (WAC) is commissioned and a WAC in range is commanded (through CSM) to "discover devices." See [Joining the ZigBee Network](#).

9. Initiate the Installation Test Mode: Momentarily press the blue Utility button under the lens. Both LEDs flash simultaneously, with one short blip of the green LED between flashes.

For dimming lights, the light is raised to the maximum level over a 3-second period then turns off, and then repeats.

For on/off lights, the light turns ON then OFF and repeats.

When operation is confirmed, exit Installation Test Mode: momentarily press the Utility button again, or wait 5 minutes for the mode to time out.



Wireless High Bay Sensor (WHS100)

Installation Process continued

10. Select a lens for the sensor according to the mounting height (see [Lens Coverage Options](#)). The 40' (HIGH) lens is pre-installed. If a change is necessary, affix the alternate lens to the sensor as described in **Lens Installation**.

If there is unwanted coverage, use the Mask provided to limit the sensor's view. Attach the mask inside the lens: align the holes in the mask with the studs under the gasket.

11. Walk test the sensor. Walk outside the coverage area and wait for the Green LED to stop flashing. Step inside the desired coverage area and observe the Green LED.

- Repeat from various positions in the coverage area.
- If you do not observe the proper behavior, see [Troubleshooting](#).

Placement Guidelines

- The PIR sensor must be 4' to 6' away from hot or cold sources such as heat or cooling vents, refrigerators, stoves, etc. Do not install the PIR sensor near strong air flows.
- The PIR sensor must have clear line of sight to the coverage area. It may not detect a human body if it is blocked by the fixture housing, furniture, plants, glass, curtains, etc.
- Secure to a stable fixture to minimize sensor vibration.

Mounting

The dimensions of the WHS100 when mounted are: 3.54" L x 3.54" W x 1.78" H (90mm L x 90mm W x 45.4mm H). The WHS100 has a threaded nipple on the side; the WHS100-BM has a threaded nipple on the base for mounting to the bottom of a fixture. In wet locations, attach the WHS100 to a watertight fixture or enclosure.

WHS100-BM base mount

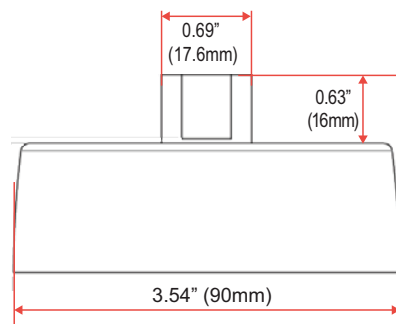

LED Operation

Red LED: Network Indicator	Description
Solid	Hardware problem.
Fast Flash (1x/sec, 1Hz)	Not connected to a ZigBee network.*
Slow Flash (1x/10sec, 0.1Hz)	Connected to a ZigBee network but not assigned to a zone.
Off	Normal operation, connected to ZigBee network and assigned to a zone.

Green LED: Motion	Description
Flash	The Green LED flashes each time sensor detects occupancy.
Off	Normal operation: not detecting occupancy.

* See [Joining the ZigBee Network](#)

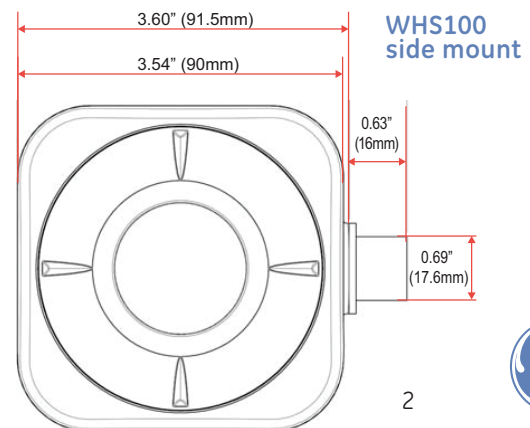
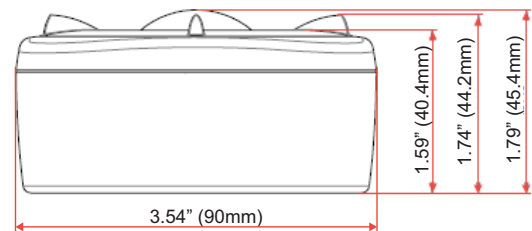
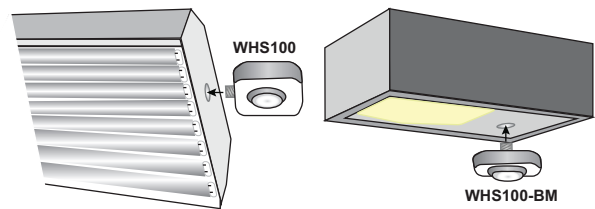

Wireless High Bay Sensor (WHS100)

Wiring

High Voltage	
Black	Active/Hot
White	Neutral
Red	Switched
Low Voltage	
Gray	Analog Ground
Violet	0-10V Analog output (dimming)

Wiring for Dimming + On/Off

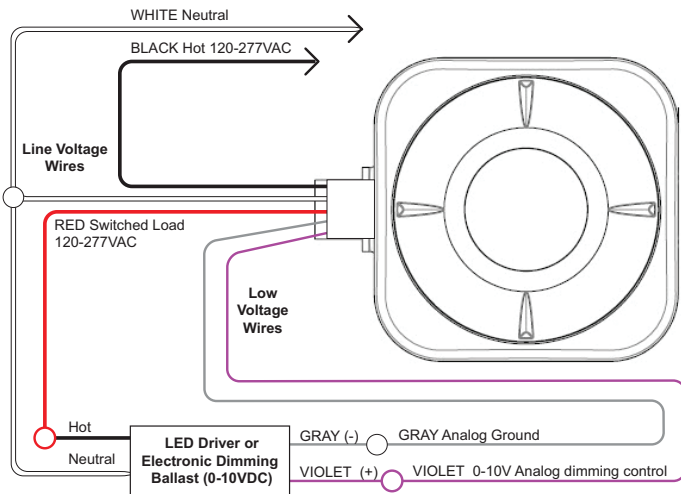

Wiring for Non-Dimming

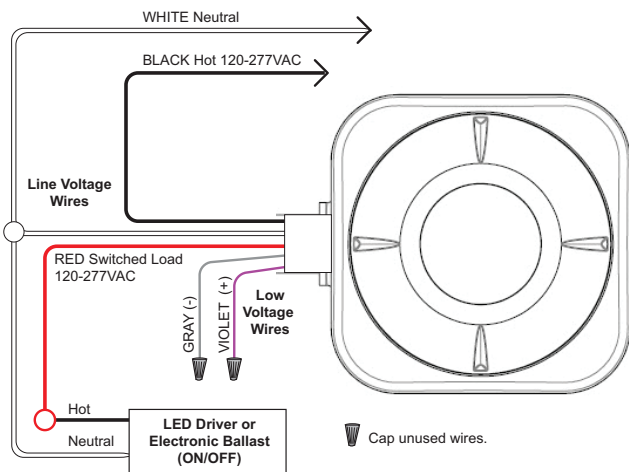

Wiring for Emergency Lighting

Emergency Fixture and Regular Fixture: Wiring to Dim while Regular Power is Available

In the wiring diagram below, the WHS100 is powered by the Regular power circuit. While Regular power is supplied, the WHS100 provides switched On/Off power to the Regular Fixture and controls dimming to the Regular and the Emergency Fixture. Loss of Regular power to the WHS100 disables dimming control, causing the emergency fixture to operate at maximum output.

The Emergency Fixture is powered by Emergency power. Loss of Regular power to the WHS100 disables the WHS100 dimming control, so the Emergency Fixture operates at maximum output.

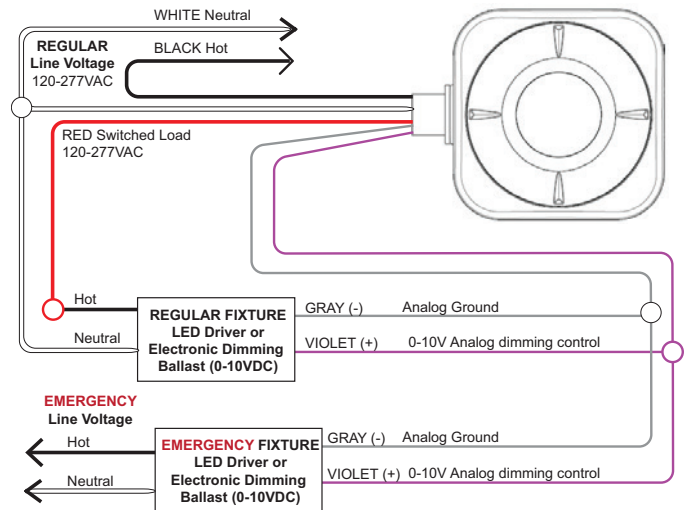

Advisory-Emergency circuit WHS-RRUX wiring 160330 document

In the diagram below, the WHS100 is powered by the Emergency power circuit. While Regular power is supplied to the RRU the WHS100 provides switched On/Off power to the fixture and controls dimming.

When the RRU senses loss of Regular power, the RRU passes Emergency power directly to the fixture and disconnects the WHS100 switched output. Loss of Regular power to the RRU-2 disables the WHS100 dimming control, so the fixture operates at maximum output.



Wireless High Bay Sensor (WHS100)

Advisory-Emergency circuit WHS-RRUX wiring 160330 document

In the diagram below, the WHS100 is powered by the Emergency power circuit. While Regular power is supplied to the RRU, the WHS100 provides switched On/Off power to the fixture and controls dimming.

When the RRU senses loss of Regular power, the RRU passes Emergency power directly to the fixture and disconnects the WHS100 switched output. Loss of Regular power to the RRU-2 disables the WHS100 dimming control, so the fixture operates at maximum output.

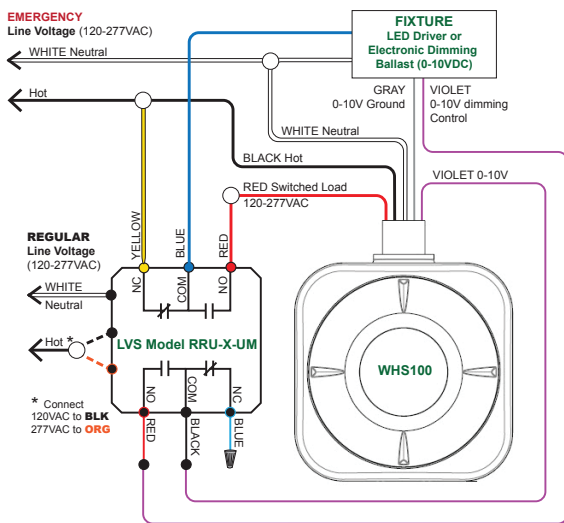

Lens Coverage Options

The PIR sensor is an indoor/outdoor device. It comes with a 40 ft lens pre-installed, two optional lenses, and a coverage mask for use in various applications. Select the appropriate lens for the mounting height and desired coverage area. The optional lenses are marked on the flange with LOW and MED for identification.

LOW bay: Height = 8 ft / Coverage radius = 20 ft

MED bay: Height = 20 ft / Coverage radius = 30 ft

High bay (unmarked): Height = 40 ft / Coverage radius = 30 ft

Use the mask to avoid occupancy triggers from activity outside the desired coverage area. Insert the mask between the inside of the lens and the inner layer of the gasket (not outside the gasket).

Changing the Lens

To maintain waterproofing a 2-layer gasket is fitted around the edge of the lens before securing the lens assembly to the sensor.

1. Remove the pre-installed lens from the lens assembly on the sensor.
2. Remove the lens gasket from the pre-installed lens.
3. Tuck the edge of the optional lens into the inner edge of the gasket, between layers.
4. Align the 4 holes on the gasket with the holes on the lens.
5. Align the holes on the lens with the studs on the inside of the cover and press the gasket assembly in place.
6. Place the lens assembly on the sensor and rotate the cover assembly clockwise to tighten it.

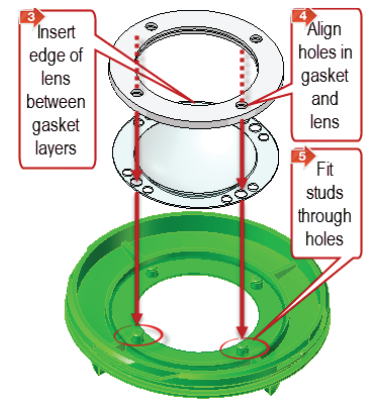
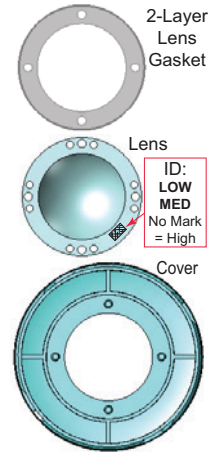

Video demonstrations of the lens mask procedures are available on Daintree Networks Partner Portal:

<http://www.daintree.net/partners/partner-portal/>

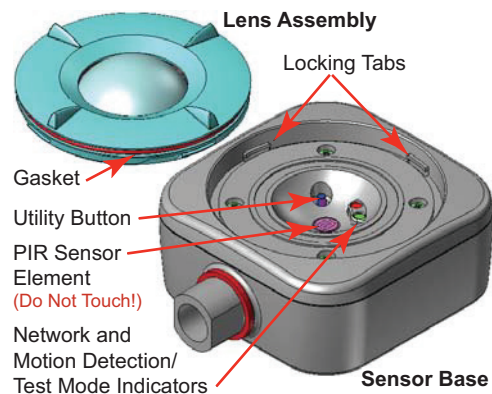

Wireless High Bay Sensor (WHS100)

Coverage Patterns

8 foot lens (**LOW**): 20 foot radius/40 foot diameter

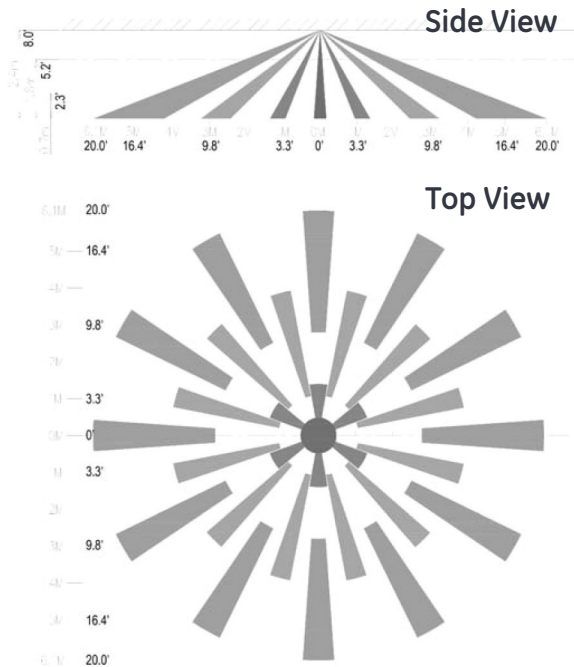

40 foot lens (**HIGH**): 30 foot radius/60 foot diameter

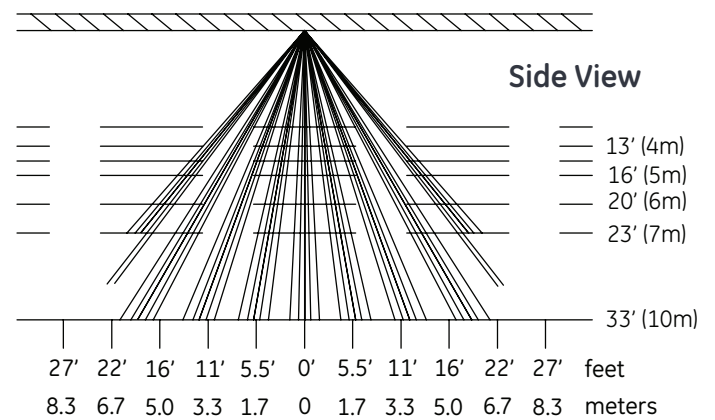

20 foot lens (**MED**): 30 foot radius/60 foot diameter

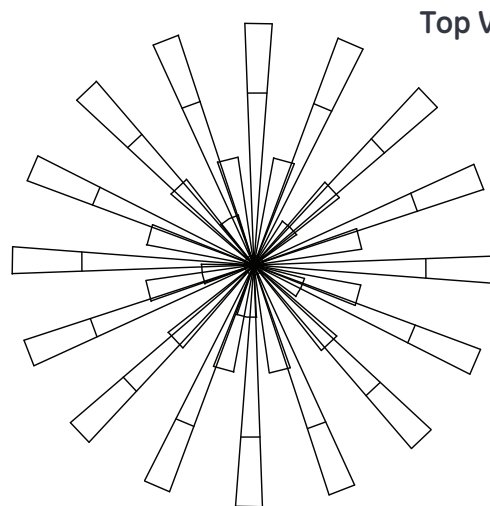
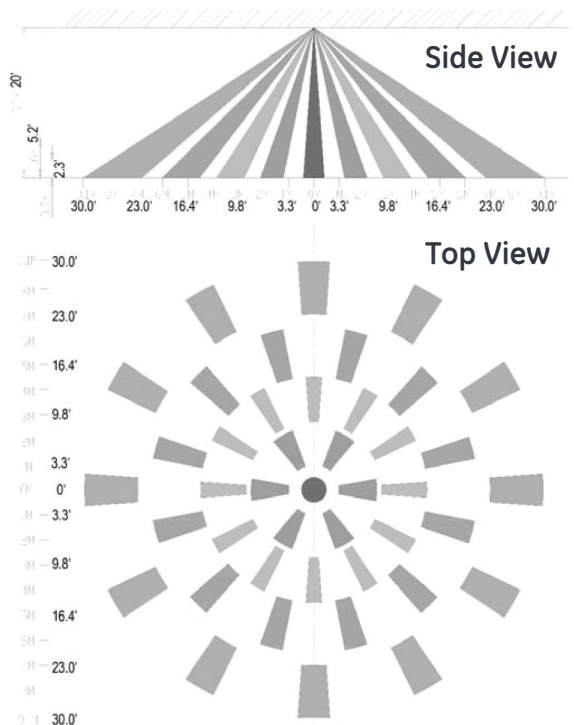

Wireless High Bay Sensor (WHS100)

Joining the ZigBee Network

After successfully completing the Installation Test the WHS100 is ready to communicate with the Daintree Wireless Area Controller (WAC) and the Daintree ControlScope Manager (CSM) web-based building controls management user interface.

A network join can be retrIGGERED manually at any time by resetting the WHS100:

- Reset to factory defaults: Press and hold the Utility button for 5 seconds. Release the button when the LEDs begin to flash rapidly. This causes the device to leave any network to which it is currently joined. Following the reset, the device attempts to join a network.

For more information about configuring the lighting control network, see the instructions and on-line help provided with the *ControlScope Manager* application.

Default Functionality

The WHS100 is designed to be part of the ControlScope network. It should not be left to operate outside of the network indefinitely. The ControlScope network provides many control efficiencies not otherwise available, including changing operational parameters.

As shipped from the factory, before it is joined to the CSM network, and after it joins the network but before it is configured into a zone, the WHS100 controls the connected light as follows:

- During occupancy light is ON at 100%
- During vacancy an on/off light turns OFF, a dimming light is reduced to 10%.
- Vacancy delay (Off Delay) is 10 minutes.

Functionality after Configured into a Zone

After the WHS100 is configured into a zone, it follows the control strategy for the zone, including delay time, light levels, and other features. The delay time is whatever the strategy dictates plus 20 seconds. For example, if the strategy is set for 8 minutes, the vacancy delay is 8 minutes and 20 seconds.

PIR Sensitivity Adjustment

There are no sensitivity adjustments on the WHS100. Contact Daintree support for information on how to change the sensor sensitivity.

Reducing noise on low voltage (0-10V) wiring

- Keep wiring as short as practical.
- Keep the signal lines separate from the mains voltage lines.
- Reduce the area created by the signal lines and the GND return (i.e., keep them close together).
- If possible twist the signal line with the GND return.



Wireless High Bay Sensor (WHS100)

IEEE Address Labels

A small plastic bag containing two small labels and the lens mask is included with every sensor. The larger label with the WHS100's full IEEE address is the Fixture label. Affix this label to the outside of the fixture or sensor in a standard location where it can be seen after installation and mounting.

Record IEEE Addresses

A marked-up copy of the facility floor plan showing the identity and location of each wireless adapter (including associated fixtures and sensors) should be available after installation. This will simplify and expedite the commissioning process.

Be sure that each sensor's IEEE address (last 5 digits) is recorded on the facility floor plan. Use the **Plan** label supplied with the adapter or write the last 5 digits on the floor plan. This information will be used during the commissioning process.

For factory installation by fixture manufacturers:

- Remove the **Fixture** label from its plastic bag, and affix to the outside of the fixture or sensor in a consistent location where it can be seen after installation and mounting.
- Leave the **Plan** label (smaller label) in its plastic bag. Tape the bag to the Fixture label or next to it.

Troubleshooting

No LEDs turn on when I press the Utility button.

- Check line voltage wiring

Light doesn't operate as expected in Installation Test Mode.

- Make sure power is turned on to the fixture circuit.
- Check all wiring between the fixture and the sensor.
- Press the blue Utility button for 5 seconds to reset the unit.

Green motion detection LED does not activate when walking through the coverage area.

- Check to see if the green LED turns on when you wave your hand directly in front of the lens.
- If the LED turns on, check for objects or barriers obstructing the sensor's view of the coverage area.

Green LED flashes when the coverage area is vacant.

- Check for sources of hot air flow in the coverage area.
- See **Placement Guidelines**. Eliminate false trigger sources.

Light doesn't turn Off after WHS100 joins the ZigBee network.

- Once the WHS100 is configured into a zone through CSM it follows the Off Delay for the zone's control strategy.

Light doesn't turn Off after WHS100 is configured into a zone.

- Check the "Off delay" for the zone in the CSM.
- Check for other CSM scheduled events or manual overrides that may be keeping the lights On.



WHS100 Wiring for Emergency Power Circuits

Appendix 1: Installation Advisory

In the diagram below, the WHS100 is powered by the Emergency power circuit. While Regular power is supplied to the LVS model RRU-X-UM, the WHS100 provides switched On/Off power to the fixture and controls dimming.

When the RRU-X-UM senses loss of Regular power, the RRU-X-UM passes Emergency power directly to the fixture and disconnects the WHS100 switched output. Loss of Regular power to the RRU-X-UM disables the WHS100 dimming control, so the fixture operates at maximum output.

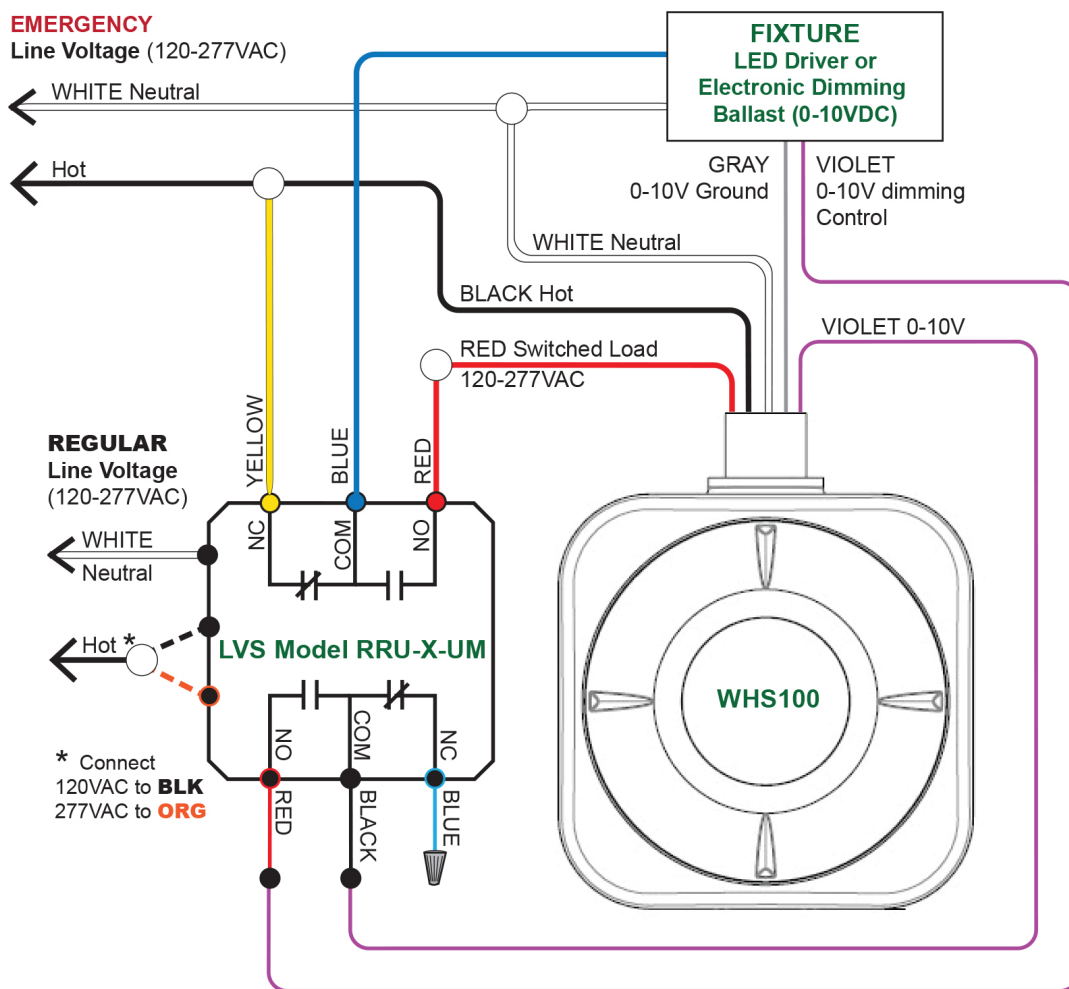

Control for Dimming ELV Fixtures: WHS100 wiring to EcoSense Linear Dimming Control Module

Appendix 2: Installation Advisory

This advisory shows the wiring connections between the EcoSense LDCM-PL and the WHS100 to provide dimming control to Electronic Low Voltage (ELV) lighting fixtures within the ControlScope system.

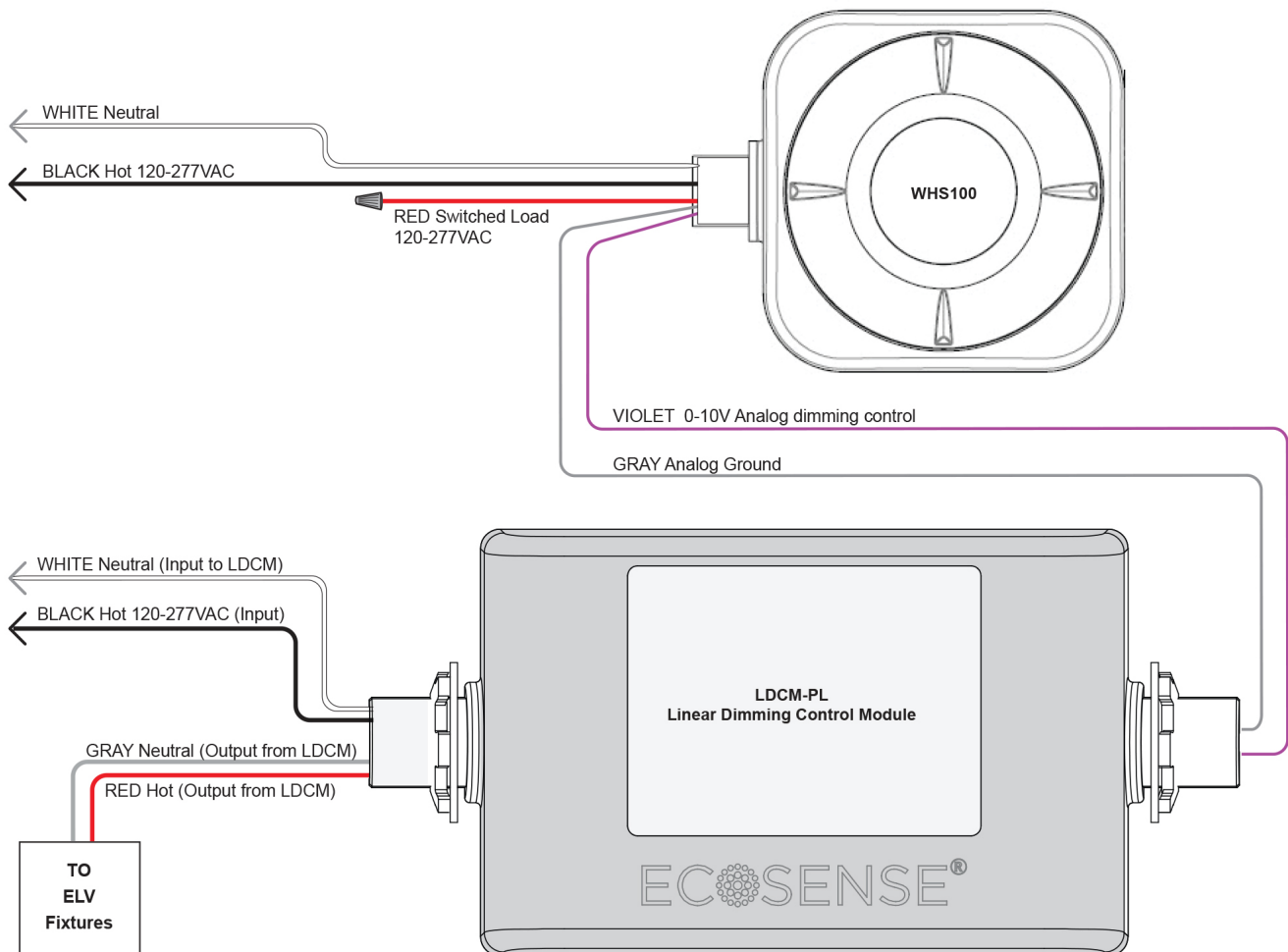

Wireless High Bay Sensor (WHS100)

FCC warning message

This equipment has been tested and found to comply with the limits for a Class B digital device, pursuant to Part 15 of the FCC Rules. These limits are designed to provide reasonable protection against harmful interference in a residential installation. This equipment generates, uses and radiates radio frequency energy and, if not installed and used in accordance with the instructions, may cause harmful interference to radio communications. However, there is no guarantee that interference will not occur in a particular installation. If this equipment does cause harmful interference to radio or television reception, which can be determined by turning the equipment off and on, the user is encourage to try to correct the interference by one or more of the following measures:

- Reorient or relocate the receiving antenna;
- Increase the separation between the equipment and receiver;
- Connect the equipment into an outlet on a circuit different from that to which the receiver is connected;
- Consult the dealer or an experienced radio/TV technician for help.

Industry Canada (IC) Warning Message

Product complies with Part 15 of the FCC Rules. Operation is subject to the following two conditions: (1) This device may not cause harmful interference, and (2) This device must accept any interference received, including interference that may cause undesired operation.

This Class B digital apparatus complies with Canadian ICES-003. Cet appareil numérique de la classe B est conforme à la norme NMB-003 du Canada.

Specifications

Input Power	120-277 VAC 50/60Hz
Load Rating	5A @ 120-277VAC
Load Types	General Use, Electronic Ballast
Ballast/Driver	Control: On/Off, 0-10V Dimming
Dimming Output	0-10V; 15mA (max sink)
Indicators	Green LED (motion detection) Red LED (off for normal operation)
Motion Sensor	PIR technology
Power Measurement	2% accuracy (0.04~5A range)
Power Consumption	0.32W @120VAC, 0.58W @277VAC
Dimensions (w/out mounting)	3.54" L x 3.54" W x 1.78" H (90mm L x 90mm W x 45.4mm H)
Radio Properties	2.4 GHz, +8dBm transmit power
Technology	Wireless: ZigBee PRO (HA, BA)
Lenses Included	360° lenses (8ft, 20ft, 40ft), Aisle Mask
Off-Delay Timer	Configurable in CSM
Operating Environment	-40°F to +158°F (-40°C to +70°C) 5-95% RH, non-condensing, Indoor/Outdoor
Enclosure	Watertight; IP66 rated*
Mounting	Standard ½" knockout mount
Compliance	FCC Part 15, FCC ID: Z6G-DT357 CAN ICES-3 (B)/NMB-3(B), IC: 10478A-DT357 UL Listed

Call **1.888.694.3533** • products.currentbyge.com

