

Wireless Occupancy Sensor, Wall Mount (WOS2-WM)

Installation Instructions

The Daintree wall mounted Wireless Occupancy Sensor (WOS2-WM) operates seamlessly within the Daintree wireless lighting control platform. The WOS2-WM is a battery-powered occupancy sensor utilizing passive infrared (PIR) sensing technology to detect movement. As part of the Daintree sensor product line and using open, standards based ZigBee wireless communications, the WOS2-WM reports real-time occupancy events to turn on lights or keep them on when movement is detected, and turn off lights when a space is vacant. The sensor's off-delay timer is user-configurable from any location using Daintree's ControlScope Manager (CSM) web application, eliminating the need for on-site, manual sensor adjustment.

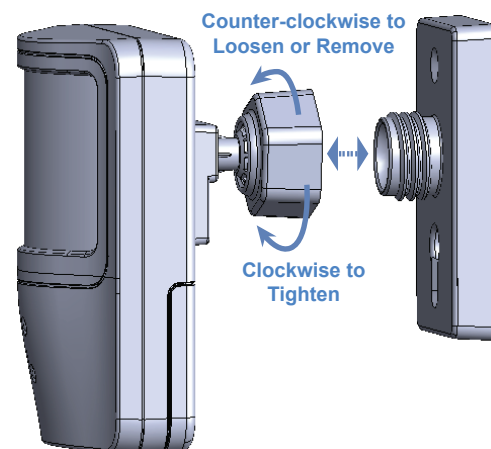
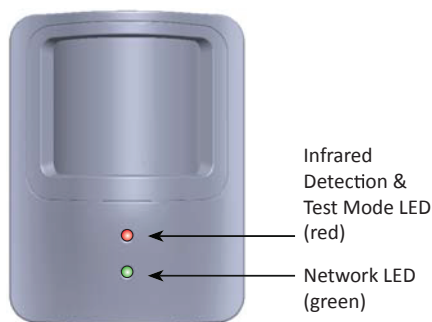

Installation Process

- Keep the sensor lens clean. Avoid touching the sensor lens.
- After first-time installation or reinstallation of a new battery, allow up to three minutes for initialization.

1. Determine the mounting location for the sensor based on the desired occupancy coverage. See **Placement** for details.

2. Attach the mounting base to the wall in the specified location.

3. Record the sensor's IEEE address and location on the facility floor plan.

4. Install the batteries in the orientation (+ -) shown on the bottom of the battery compartments.

5. Attach the sensor's main unit to the ball socket on the mounting base. Adjust the angle of the sensor, then hand-tighten the collar to secure the angle.



6. After the batteries have been installed for at least 3 minutes, initiate the Installation Test Mode: Momentarily press the Utility button. The green LED flashes once, then the red LED flashes each time the sensor detects motion. (The test mode times out after 5 minutes.)

- A. Walk test the sensor. Walk outside the coverage area and wait for the red LED to stop flashing. Step inside the desired coverage area and observe the red LED.
- B. Repeat from various positions in the coverage area.
- C. If necessary, adjust the sensor as described in **Adjustments: PIR Sensitivity**. Repeat the walk test.
- D. If you do not observe the proper behavior, see **Troubleshooting**.



Wireless Occupancy Sensor, Wall Mount (WOS2-WM)

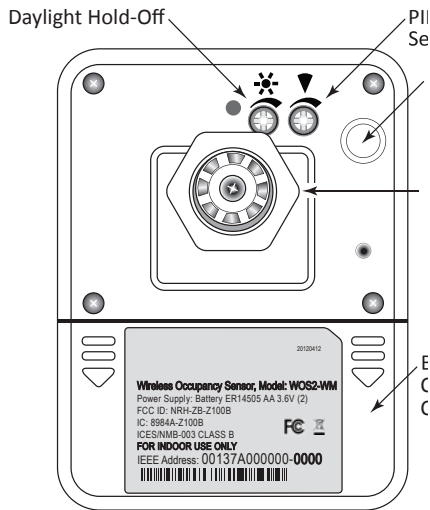

Red LED: Installation Test Mode, Motion	Description
While unit is in Installation Test Mode, Flashes	The red LED flashes each time sensor detects occupancy. Test mode times out after 5 minutes.
Off	Normal operation: either not detecting occupancy, or detected occupancy and in Off Delay. LED turns on with initial occupancy.

7. Exit Installation Test Mode. Momentarily press the Utility button again, or wait 5 minutes for the mode to time out.

8. The sensor attempts to join a ZigBee network for up to 30 seconds. If it is able to join, the Network LED turns on solid for 10 seconds. If it is unable to join, it automatically retries every 15 minutes until it succeeds in joining a network. Note, the sensor will not be able to join a network until a Wireless Area Controller (WAC) is commissioned. See [LED Operation](#) and [Joining the ZigBee Network](#).

LED Operation

Green LED: Network Indicator	Description
Rapid flash (12 times per second) for up to 30 seconds	Device is trying to join ZigBee network. If it fails to join, it will retry after 15 minutes.*
Solid for 10 seconds	Device successfully joined a ZigBee network.
Flashes once	Utility button was pressed to initiate Installation Test Mode.
Flashes twice	Utility button was pressed for 2 seconds and the device is currently joined to a network.
On for 2 seconds every 30 seconds	The batteries are low; replace the batteries. Also, see alert on CSM.

* A network join can be retrigged manually at any time using one of the following methods:

- **Reset to factory defaults:** This causes the device to leave any network to which it is currently joined. Following the reset, the device attempts to join a network. Press and hold the Utility button for 5 seconds. Release the button when the Network LED begins to flash rapidly.
- **Activate device:** Press and hold the Utility button for 2 seconds. If the device is already joined to a network, the Network LED flashes twice. If the device is not joined to a network, the Network LED flashes rapidly and the device will attempt to join a network.

For more information about configuring the lighting control network, see the instructions and on-line help provided with the CSM application.

Joining the Zigbee Network

After successfully completing the Installation Test the occupancy sensor is ready to communicate with the Daintree Wireless Area Controller (WAC) and the Daintree CSM web-based lighting management user interface.

For more information about configuring the lighting control network, see the instructions and on-line help provided with the CSM application.



Wireless Occupancy Sensor, Wall Mount (WOS2-WM)

Placement

The PIR sensor can only be installed indoors. It is extremely important to select the appropriate installation location to avoid false occupancy reporting while obtaining the best sensitivity. A proper installation should meet the following conditions:

- The PIR sensor is typically mounted 6.5' to 10' (2m to 3m) from the floor, with a 15 degree vertical tilt. The height, tilt, and angle of the installation affects the coverage area.
- The PIR sensor must be 4' to 6' away from hot or cold sources such as heat or air conditioner vents, refrigerators, stoves, and so on. The PIR sensor should not be installed in places with strong air flows.
- The PIR sensor must have clear line of sight to the coverage area. It may not detect a human body if it is blocked by furniture, fixtures, large plants, glass, curtains, and so on.
- Install the detector securely to the ceiling or wall to minimize sensor vibration. The PIR sensor should not be installed on doors or windows, nor exposed to direct sunlight. The resulting hot air and/or motion can cause false activation.
- The effectiveness of the PIR sensor is highly related to the direction of human motion.

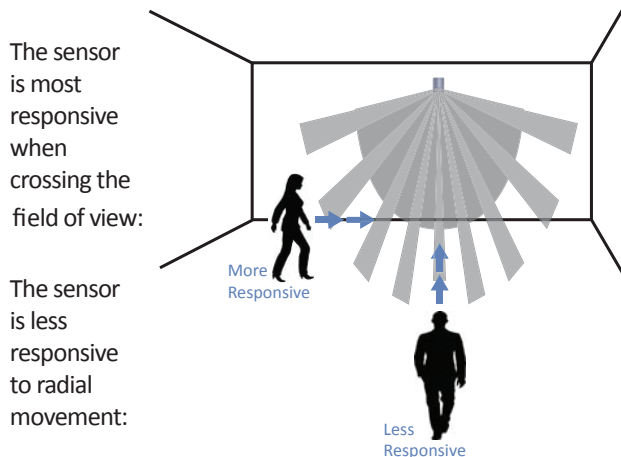

WOS2-WM-W (wide-angle)	
Installation Height	6.5' to 10' (2m to 3m) from floor
Installation Angle	15° tilt toward floor
Detection Angle	110°
Detection Range	up to 36' (11m)

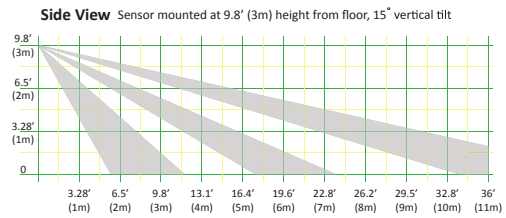
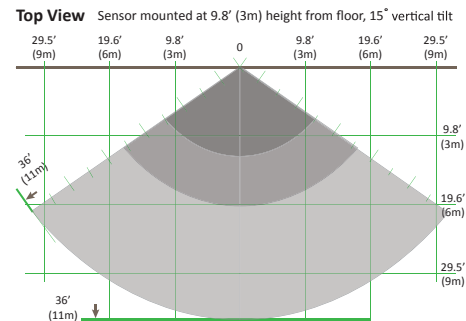

WOS2-WM-L (long range)	
Installation Height	6.5' to 7.2' (2m to 2.2m) from floor
Installation Angle	15° tilt toward floor
Detection Angle	20° / 30 meters
Detection Range	6.5' to 98.4' (2m to 30m)

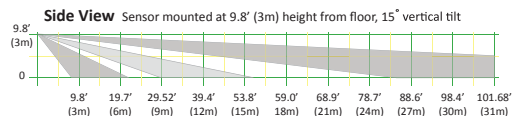
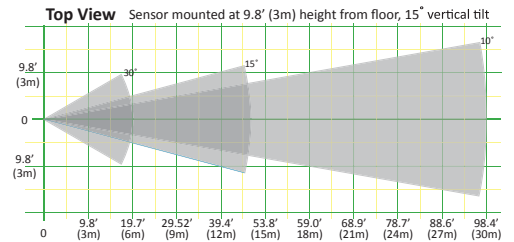

Wireless Occupancy Sensor, Wall Mount (WOS2-WM)

Adjustments

Two trimpots on the back of the sensor are used to adjust the Daylight Hold-Off threshold and PIR motion sensor sensitivity. For easier access to the trimpots after the sensor has been mounted, remove the sensor from the mounting bracket.

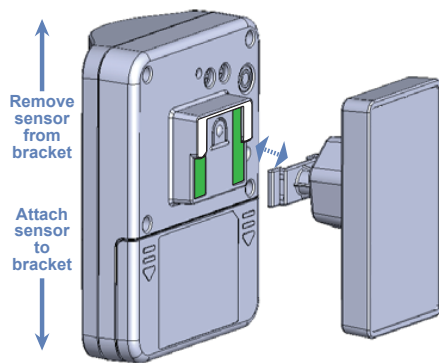

Use caution when adjusting the trimpots. Do not use excess force, as this will damage the unit. Stop turning the trimpot when you feel resistance.

PIR Sensitivity ▼

Turn the trimpot clockwise to increase sensitivity. Turn the trimpot counter-clockwise to decrease sensitivity.

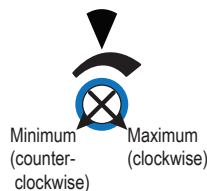

To test the daylight hold-off after the installation is complete and the sensor has been added to CSM:

1. Ensure that CSM's control strategy for this zone makes use of occupancy sensors and has the 'Enable Daylight hold-off' check box selected.
2. Wait until vacancy is detected and the lights turn off.
3. Trigger occupancy while the light level is below the selected threshold. The lights should turn on. Trigger occupancy while the light level is above the selected threshold. The lights should remain off.

Troubleshooting

No LEDs turn on when I press the Utility button.

- Check battery installation.
- Make sure batteries are oriented (+ -) correctly.

The red Infrared Detection LED does not activate when walking through the coverage area while in Installation Test mode.

- Check to see if the red LED turns on when you wave your hand directly in front of the lens.
 - If the red LED turns on, adjust the PIR Sensitivity trimpot clockwise to increase sensitivity. Check for objects or barriers obstructing the sensor's view of the coverage area.
 - If the red LED does not turn on, the Installation Test mode may have timed out. Restart the Installation Test mode by momentarily pressing the Utility button. The green LED turns on briefly, then the red LED flashes with each detection. Installation Test mode times out in 5 minutes.

The red LED flashes when nobody is moving in the coverage area.

- Adjust the PIR sensitivity trimpot counter-clockwise to reduce sensitivity. Repeat the walk test.
- Check for sources of hot airflow in the coverage area.
- Review the Placement guidelines and eliminate false trigger sources.

If lights do not turn Off after the WOS2-CM has Joined the ZigBee network:

- Check the "Off delay" for the zone in the Daintree CSM.
- Check for other CSM scheduled events or manual overrides that may be keeping the lights On.



Wireless Occupancy Sensor, Wall Mount (WOS2-WM)

FCC warning message

This equipment has been tested and found to comply with the limits for a Class B digital device, pursuant to Part 15 of the FCC Rules. These limits are designed to provide reasonable protection against harmful interference in a residential installation. This equipment generates, uses and radiates radio frequency energy and, if not installed and used in accordance with the instructions, may cause harmful interference to radio communications. However, there is no guarantee that interference will not occur in a particular installation. If this equipment does cause harmful interference to radio or television reception, which can be determined by turning the equipment off and on, the user is encouraged to try to correct the interference by one or more of the following measures:

- Reorient or relocate the receiving antenna;
- Increase the separation between the equipment and receiver;
- Connect the equipment into an outlet on a circuit different from that to which the receiver is connected;
- Consult the dealer or an experienced radio/TV technician for help.

Industry Canada (IC) Warning Message

Product complies with Part 15 of the FCC Rules. Operation is subject to the following two conditions: (1) This device may not cause harmful interference, and (2) This device must accept any interference received, including interference that may cause undesired operation.

Specifications

Power Supply	(2) Lithium-thionyl chloride batteries (Li-SOCl ₂) AA 3.6V (included)
Battery Life	5 years (normal operation)
Radio Properties	2.4 GHz, +7dBm transmit power
Sensor Coverage (maximum)	110°, 11 m/36 (WOS2-WM-W) 20°, 30 m/98 (WOS2-WM-L)
Off-Delay Timer	30 seconds (fixed), additional delay time configurable in CSM
Operating Environment	14°F to +122°F (-10°C to 50°C) Indoor use only
Compliance	FCC Part 15B, FCC ID: NRH-ZB-Z100B ICES/NMB-003 Class B, IC: 8984A-Z100B
Mounting	(2) Screw holes on swivel mount bracket; wall (or ceiling) mount
Dimensions	3.6" W x 2.8" H x 3" D (92mm W x 70mm H x 77mm D) Weight (without battery): 3.32 oz. (94g)

